



Reenergy Power is a leading manufacturer of high-quality lithium-ion and VRLA batteries, catering to the growing demand for efficient and sustainable energy storage solutions. Our batteries are designed for a wide range of applications, including renewable energy systems, and industrial equipment, for residential and commercial applications.

We are committed to innovation, reliability, and environmental sustainability. Reenergy Power aims to provide durable, high-performance batteries that empower a greener and more connected world.

■ RPHV-3C

RPHV-3C offers 61.44kWh capacity and also features intelligent temperature control to enhance safety and extend the system's lifespan. With an integrated BMS, it allows for real time monitoring and enhanced battery performance..



Product Details



Grade A LifePo4 Cell



Safety & Reliability

- LiFePO4 battery technology for enhanced safety and extended lifespan
- 1+1 redundant design for improved reliability
- Equipped with air conditioning, cooling fans, and fire extinguishing system for optimal safety and temperature control in the battery module.



Flexibility

- Standard modular design with 5.12kwh per battery module.
- Flexible design from 4-14 battery modules in series.



Cost Effective & High Efficiency

- 100% Depth of Discharge (DOD) for maximum energy usage
- Enhanced return on investment through optimized performance.



Simple & Friendly

- Pre-installed before delivery for easy and quick installation.
- Backup time ranging from 2 to 5 hours



Convenience

- Standard 19-inch rack design for easy installation & maintenance.
- Supporting USB software upgrade

- Three-layer architecture with integrated BMU, RBMS, and SBMS for enhanced multi-level protection.
- Touchscreen interface for selecting different communication protocols.
- High modularity degree, simple structure, easy installation and maintenance.
- Integrated self-developed BMS for real-time monitoring and management.
- Supports up to 10 energy systems in parallel, allowing maximum scalability.
- PACK level fire-fighting System(optional).
- Comprehensive battery protection strategy with fault detection and isolation measures to ensure energy storage system safety.
- Utilizes mature, safe, economical, environmentally friendly lithium iron phosphate battery modules with an ultra-long lifespan and high reliability

Technical Specifications	
Items	Description
Module Energy	5.12kWh
Module Nominal Voltage	51.2V
Module Capacity	100A
Battery Module Qty 1 in series	12
System Nominal Voltage (V)	614.4V
Charge Voltage(V)	662.4V~691.2V
Cut-Off Discharge Voltage(V)	518.8V
Float Charge Voltage(V)	652.8V~662.4V
System Energy	61.44kWh
Recommended Depth Of Discharge	90%
Storage Temperature	0°C~45°C
Communication Port	CAN/RS485
Status Indicator	RUN-Green Light; Alarm-Red Light
IP Rating Of Enclosure	IP20
Dimensions [mm](W*D*H)	800*1300*1500
Installation Location	Rack/Cabinet,Indoor
Cycle Life	8000 50% DOD, 6000 times 80% DOD, 4000 100% DOD (0.2, 25°C)
Warranty	5 Years
Certification	IEC62619,UN38.3,MSDS

- Independent intelligent temperature control system minimizes temperature variations between modules, prolonging battery life.

System Diagram

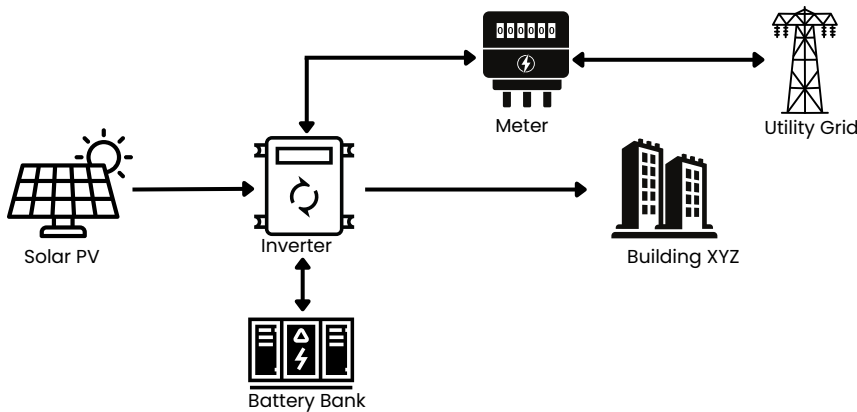

Contact us



(0044) 19089 20612



www.reenergypower.com



support@reenergypower.com



500 Avebury Boulevard, Milton Keynes, Buckinghamshire, MK9 2BE, United Kingdom



RPHV-3C

REENERGY POWER LIMITED is registered company in England and Wales under number 10115425